



## REAR TOE LINK KIT INSTALLATION INSTRUCTIONS

PART NUMBER D280-0025

APPLICATION:	2022-23	G42 M240i & xDrive
	2022-23	G42 230i & xDrive
	2020-23	G20 M340i & xDrive
	2019-23	G20 330i & xDrive
	2021-23	G22/G23 M440i & xDrive
	2022-23	G26 M440i & xDrive
	2021-23	G22/G23 430i & xDrive
	2022-23	G26 430i & xDrive
	2019-23	G29 Z4 30i
	2020-23	G29 Z4 M40i
	2020-23	A90/A91 Supra 3.0L
	2021-23	A90/A91 Supra 2.0L

Congratulations on being selective enough to use a Dinan Rear Toe Link Kit. We have spent many hours developing this kit to assure that you will receive maximum performance and durability with minimum difficulty in installation. Please take the time to read these instructions and call us if you have any difficulties during the installation.

**DO NOT WORK ON VEHICLES SUPPORTED BY A JACK ONLY. USE SECURE JACK STANDS!**

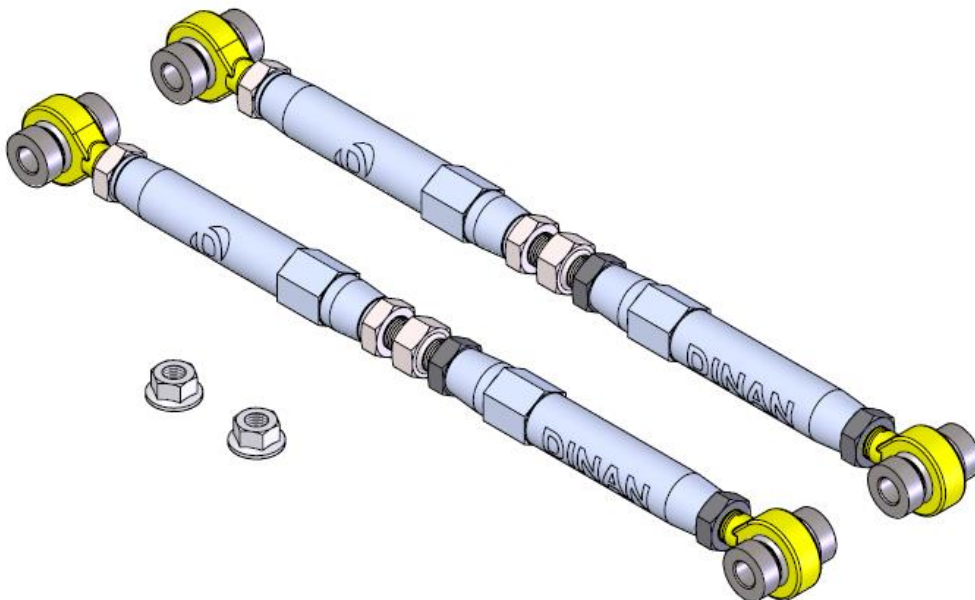

---

## PARTS LIST

Qty	Part #	Description
2	D283-0039	Toe Link/Boots Assy
2	33 32 6 760 668	Nuts w/ flange

---

### INSTALLATION NOTES:

- Some hardware may need to be replaced. Please review the factory procedure and have those pieces on hand as needed.
- An alignment will be required after installation of these links.

### INSTALLATION:

1. Remove rear wheels.
2. Mark the positions of the toe adjustment eccentric bolts.
3. Remove the stock rear toe links per factory recommended procedure.
4. The two Dinan toe links have been preset to the correct length and do not require adjustment at this time.
5. Install the Dinan rear toe links.
  - Be sure to start the bolts by hand a few turns first, to prevent cross-threading.
  - Use the new nuts provided.
6. Take care to align the eccentric bolts with the marks made in Step 2.
7. Torque fasteners to 74 ft-lbs.
8. Perform an alignment. There is no need to use the factory eccentrics to adjust the rear toe. Adjust rear toe using the Dinan toe link for improved precision.
  - While holding the two main sections steady, loosen the two jam nuts on either side of the center turnbuckle. Note that the nut near the “D” logo section has left-hand threads.
  - Turn the center turnbuckle to adjust the overall length of the toe link.
  - Tighten jam nuts.

