

DINAN'S E9x M3 EXHAUST

By Steve Dinan

After many months of development and far too many dyno-runs to count, our Free Flow Exhaust for the E9x M3 is now shipping. I couldn't be happier with the finished product as our team of engineers was able to accomplish every goal I had established for the performance muffler: improved flow for increased power, reduction of weight, a "throaty" exhaust note and a purposeful high performance look. As our M3 exhaust employs a unique design approach in order to accomplish our objectives, I thought that a more technical discussion on the subject might be of interest to performance enthusiasts. This paper will discuss a bit of general exhaust theory, the specific approach we have employed for the E9x M3 exhaust, as well as attempt to dispel some common misconceptions about exhaust tuning.

Exhaust Theory

There are three major areas of the complete exhaust system that are typically tuned for enhanced performance; the exhaust manifold with catalyst or header, the middle exhaust section with catalyst, and the rear muffler(s). The exhaust manifold's length, tubing diameter and the manner in which each cylinder is linked to the other is critical when attempting to maximize an engine's power output. The manifold configuration can be manipulated in order to generate maximum power throughout the entire RPM range, changing the shape of the power curve accordingly. Naturally some compromise must be accepted when tuning an exhaust manifold for a street-car as the goal is typically to ensure balanced power output at low, middle and high rpm. This is in contrast to a race-engine where the exhaust manifold can be tuned specifically for maximum performance at high rpm.

After the exhaust manifold or header, optimum performance comes from making the balance of the exhaust system as short and large as possible. This approach will result in greater engine efficiency for maximum power, as well as minimizing the weight of the system. Probably the best example of an optimized, no-compromise exhaust system would be that of an F1 racecar. If you have ever had the opportunity to hear a F1 exhaust note, I think you will agree that it is best described as deafening. Clearly an exhaust system that even approached such a volume level in a performance street-car would draw far too much of the wrong sort of attention. Therefore, a modern street-car exhaust represents a number of performance compromises in order to achieve an acceptable exhaust volume, as well as meeting emissions standards. In order to accommodate the various components and baffling necessary for a street-car, the exhaust system becomes longer and the flow of gasses more circuitous as noise and emissions standards are addressed. Each bend in the exhaust tubing, catalytic converter, resonator and so forth introduces restrictions to the exhaust flow, particularly at higher rpm where flow is most critical. Exhaust flow can actually reach hundreds of miles per hour when the engine is producing maximum power, which results in power robbing friction along the exhaust tubing walls, particularly when the gasses must change direction. This friction results in increased backpressure that can be quantified with a pressure gauge. This backpressure restricts the amount of gasses that can be passed through the engine, resulting in a reduction of peak power. I'm fairly certain that many of you have been exposed to a "bench racing legend" that would have you believe that increased backpressure will improve low rpm power and that low backpressure will increase high rpm

output. Nothing could be further from the truth. An exhaust system is sized for maximum flow at wide-open-throttle and peak rpm. All exhaust systems are “oversized” for lower engine speeds (rpm), as backpressure is so insignificant that it can’t even be measured. Less backpressure always results in more power at higher rpm, with no negative effect on lower engine speed performance. The amount of power that can be extracted from an engine at a given rpm as a result of exhaust design is really limited by the exhaust manifold or header. After the header, less backpressure is always better. The real challenge when tuning a street-car exhaust is to increase flow without making the system loud or eliminating catalyst that will prevent you from registering your car because of your local emissions standards. It is also important to understand that vehicle manufacturers must meet more stringent maximum noise requirements than aftermarket manufacturers.

Headers have become very popular in recent years because they make substantial power gains. The real reason they gain power has more to do with eliminating the front catalyst that is built into the header than the header itself. Modern M Cars have very high quality well tuned headers but to meet the emissions standards, there are four catalysts, two in the header and two more in the center exhaust section. The two three-way catalysts on the header are monitored by secondary O2 sensors to report catalyst efficiency to the ECU. There are two more catalysts mounted under the floor before the resonator and are not monitored by the O2 sensors for catalyst efficiency. The front catalysts mounted on the header are usually twice as restrictive as the rear catalysts and are as close to the engine as necessary to light off cold to improve exhaust emissions on cold start.

Moving on to the rear exhaust or mufflers, BMW’s current M-cars feature a distinctive quad exhaust tip design, punctuating the car’s high performance image. This approach is very logical when applied to a “V” engine configuration because there are natural dual exhaust outputs with this engine design, as indicated in the following diagram.

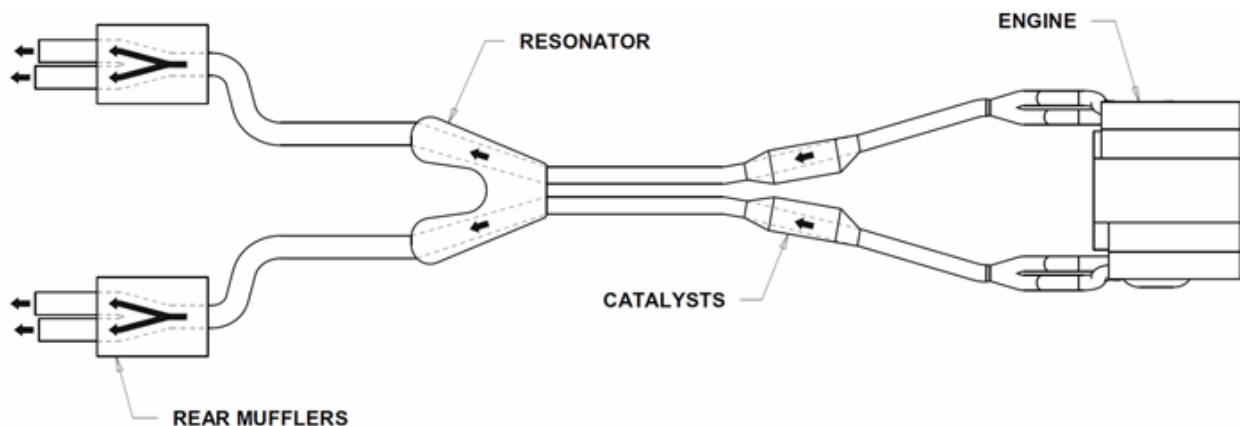

Rear Exhaust Design Approach

When it comes to the E90-92 M3 muffler, however, the vehicle design did not lend itself to the more traditional twin muffler approach, necessitating a cross-over within the single muffler case in order to feed the four tips and reduce noise to an acceptable level. This design requires that the

exhaust flow has two 90 degree bends in each side plus a “Y” pipe on each side to go from one input pipe to two tailpipes per side. These turns and “Y” pipes as indicated in the following diagram, increase back pressure.

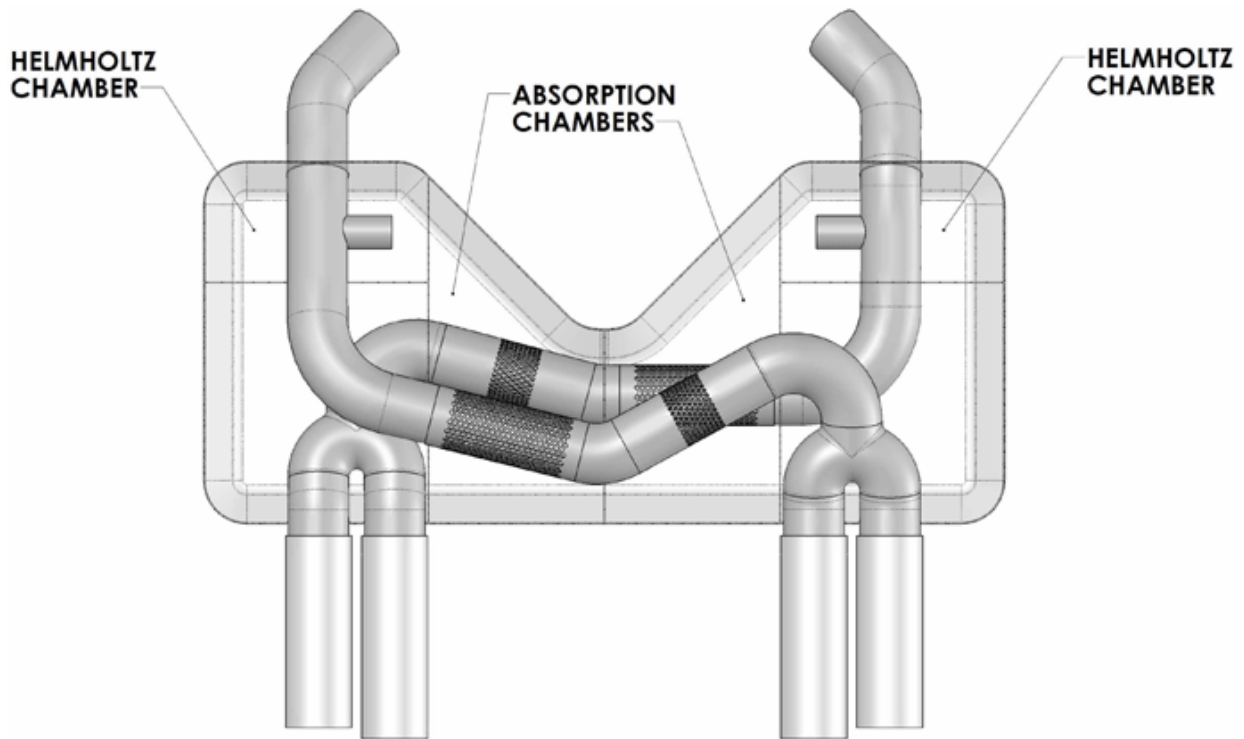

E90/E92 M3 STOCK REAR MUFFLER

Months of testing demonstrated conclusively, that requiring exhaust gasses to make four 90 degree turns within the stock muffler’s internal chamber results in a increase in back-pressure. The stock exhaust also incorporates a Helmholtz chamber within the muffler to tune low frequency drone out of the exhaust. During development it became obvious that the Helmholtz chamber would be necessary to maintain reasonable noise levels. In addition the “Y” pipe at the tail-pipe amplified the low frequency drone when compared to a single straight pipe.

Because of power robbing turns and weight it was decided the mufflers needed to be straight trough with no bends or turns within the muffler case. Also because of low frequency drone it would also be necessary to incorporate a Helmholtz chamber within the exhaust. With this combination we had power, light weight, reduced noise and low cost. All the things you are looking for in a high performance exhaust. However once we incorporated a “Y” pipe at the tail pipe like the original BMW design to make quad exhaust tips the low frequency drone came back. It was possible to make the drone go away with the 4 - 90 degree turns like BMW used but we lost significant power with a large increase in weight and cost. Or it was possible to get good flow and a low frequency drone with 4 tailpipe tips, but it was impossible to get both. We considered using an external Helmholtz chamber like some companies have done. But this added additional weight and cost and was deemed unacceptable. Analyzing other after-market

manufacturer's mufflers revealed that they had all made a compromise because of these problems. Either they had high backpressure from keeping the BMW design or very loud low frequency drone with straight through twin muffler designs or heavy expensive exhausts with straight through designs and external Helmholtz chambers. Despite mounting pressure from M3 owners to deliver the Dinan exhaust, we made a conscious decision to continue working toward a design that accomplished our stated objectives. While we certainly would have preferred to begin shipping the systems sooner, I simply won't accept compromises when it comes to performance.

We worked and worked at designs that would maintain the dual exhaust outlets but each iteration resulted in a heavy, low frequency drone with far too much back-pressure to produce any substantial power gains. After analyzing many designs, we came to the conclusion that a more radical approach was required in order to produce a truly high performance exhaust. Further pressure tests and dyno runs confirmed our suspicions about the best approach for the M3 muffler. Adopting a completely new design approach resulted in a significant improvement in flow. The exhaust note became throaty and aggressive, without being loud. Weight was reduced from 56 to 41 lbs. As you can see from the diagram below, our M3 exhaust utilizes the one active outlet per side. Recognizing that the four tips have become a significant visual design element for modern M-cars, as well as the fact that the rear valance has a cut out to accommodate four tips, both sides have a second tip that is inactive. While they are non-functional, the M-car look is retained without compromising performance. The 3" tips have been ceramic coated black for a striking high performance look, while eliminating any concern over uneven discoloration that would occur with polished stainless.

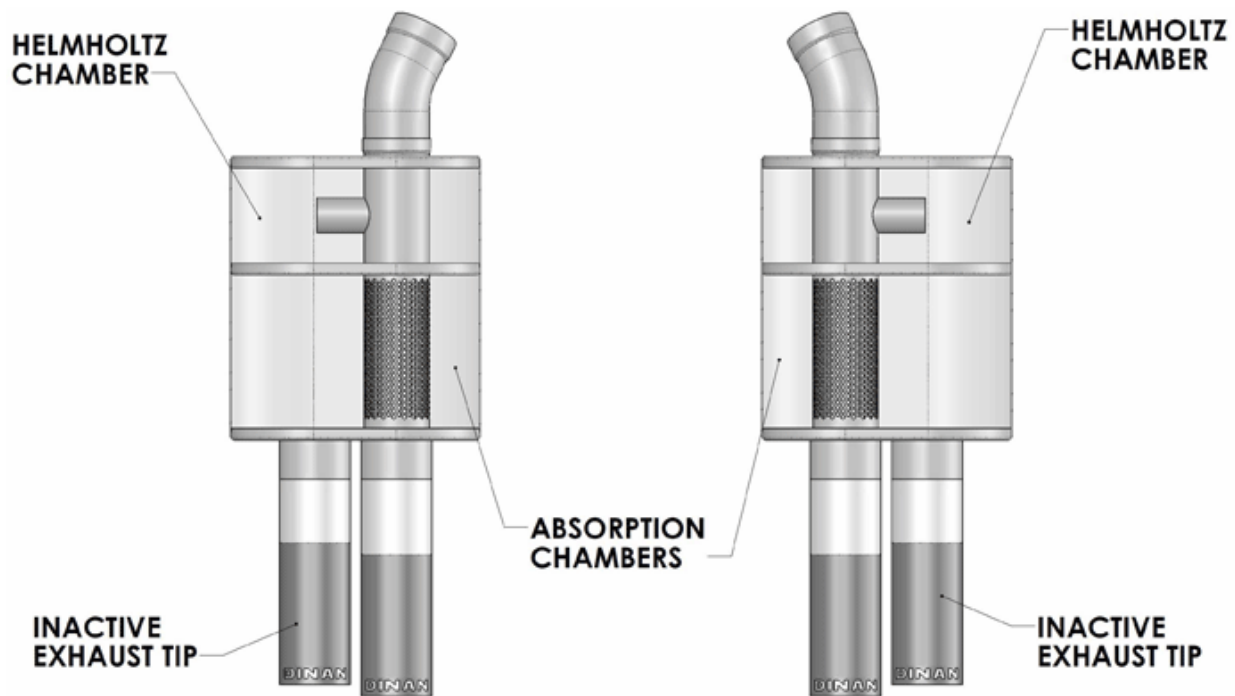

E90/E92 M3 DINAN MUFFLERS

The system produces measurable power gains, looks great, is light weight, low cost and produces the exhaust note M3 owners have been waiting for. I believe that this latest exhaust design underscores the importance of real engineering and extensive testing. The end result is BMW-like fit and finish combined with the best warranty in the business, and makes for the definitive solution for your high performance M3 exhaust.